

MPM-L75U-M Adjustable Mobil Cart With Metal Shelf

For Montitors Up To 150 lbs

Best In Class Mobil Cart Mounting Solution

- Universal design
- VESA compatible
- Continuous vertical position adjustment for perfect viewing height
- Pin-locking incremental tilt adjustment
- Heavy-duty rubber casters for smooth mobility
- Metal component shelves easily attach after display is installed
- Integrated cable management for clean look
- Pre-sorted hardware pack for easy installation



Model	Display Size*	VESA	Max Height	Max Load
MPM-L75U-M	37" - 70"	723x501mm	70.75"	150lb

* Display size is meant as a guide – Compatible display sizes can be larger or smaller depending on the VESA and weight of the display.



HEAVY DUTY CASTERS & CABLE MANAGEMENT

Rubber Casters for Smooth Mobility

Heavy duty rubber casters provide for soomth mobility even when at full weight capacity, while an integrated cable management system provides for a clean look.

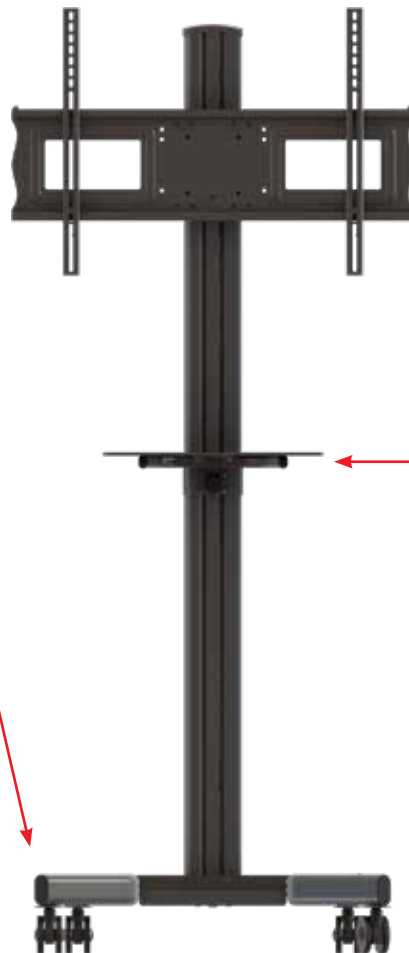

CONTINUOUS TILT

+15/-5 Degree Tilt

The mounting plate has continuous tilt of up +15/-5 degree for ideal display placement.

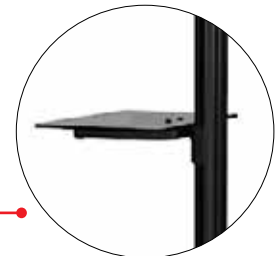

SHELVING ACCESSORY

Adjustable Tempered Metal Shelf

Designed with A metal (MPMS-M) attachable shelf the MPM-L75U-M can support up to 50lbs of additional components.

MPM-L75U-M Adjustable Height & Tilt Mobil Cart

Mustang AV
www.mustangav.com

Universal design for 37" - 70"+ displays*
Metal shelf included



Attribute	Value
Recommended display size*	37" - 70"
Weight capacity	150lb (54kg) per display
Max mounting pattern	723 x 501mm
Min mounting pattern	75x75mm
Orientation	landscape or portrait
Tilt	+15°/-5°
Depth from wall	2.90" (74.50mm)
Max display height	70.75"
Lateral adjustment	6° (lockable)
Construction	high-grade cold rolled steel
Product finish	scratch resistant epoxy powder coat
Color	black
Model number	MPM-L75U-M
Warranty	5 year limited

Universal design and heavy duty construction makes this cart ideal for Plasma, LCD or displays weighing up to 150 lb. Comes with heavy duty rubber casters for smooth mobility. Fits through standard door openings. Fully adjustable tilt and display height position. Vertically adjustable tempered glass or metal shelf can be easily installed or removed without removing display.

