

# MPDS-M44UL Bolt Down Security Table Stand

## Universal Mount For 32-55" Displays\*

### Best In Class Security Table Mounting Solution

- Integrated security at every connection point and proprietary one touch lock and key system makes this the most secure stand on the market
- 30° or 45° degree swivel lock prevents over-rotation and possible collision with wall or furniture
- Through column cable management allows for cables to be routed through the mounting surface and out of the way of hotel guests
- Universal design fits displays from 32"-50" with VESA patterns from 100x100mm through 400x400mm



Model	Display Size*	Max VESA	Total Load
MPDS-M44UL	32" - 55"	400 x 400mm	150lb

\* Display size is meant as a guide – Compatible display sizes can be larger or smaller depending on the VESA and weight of the display.

#### ANTI-THEFT & ANTI-TAMPER SECURITY

##### Security Covers

Block access to monitor attachment points and prevents removing or tampering

##### Proprietary Lock & Key Security

One-touch lock system prevents removal of display. Provides a deeper level of security than standard security screws. Laser cut keys can not be duplicated

##### Recessed Security Screw

Prevents access to surface attachment point without a special tool

#### SMOOTH SWIVEL

##### Swivel Regulator

Set the swivel angle at 30° or 45° to prevent collisions with wall or other furniture

#### CABLE MANAGEMENT

##### Through-Column

Cables may be run from display to either the bottom of the stand or all the way through the mounting surface and completely out of sight

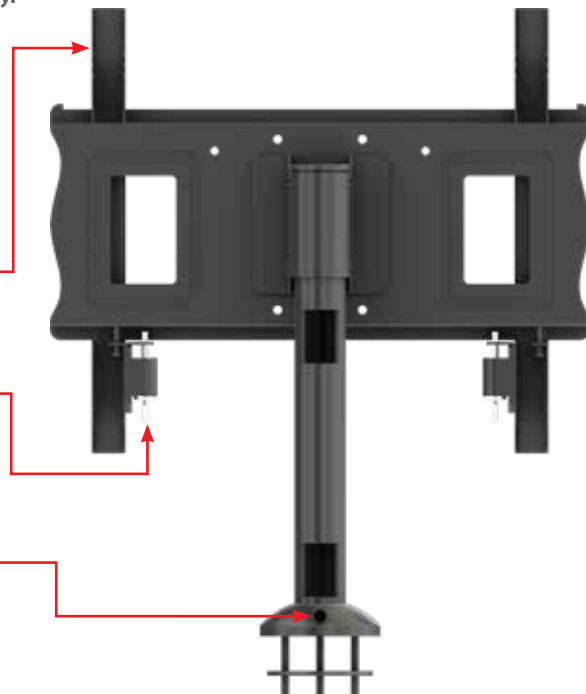

# MPDS-M44UL Security Table Stand

Universal bolt down mount for 32" - 55" displays\*



Attribute	Value
Recommended display size*	32" - 55"
Weight capacity	150lb (68kg)
Max mounting pattern	454x400mm
Min mounting pattern	75x75mm
Orientation	Varies with display
Construction	Aluminum/high-grade cold rolled steel
Product weight	29.7lb (11.6kg)
Product finish	Scratch resistant epoxy powder coat
Color	Black
Model number	MPDS-M44UL
Warranty	5 year limited

Bolt down security table stand. Integrated security at every connection point and proprietary one touch lock and key system makes this the most secure stand on the market. 30 degree or 45 degree swivel lock prevents over-rotation and possible collision with wall or furniture. Single display desktop stand with Universal display adapter holds monitors weighing up to 150lb. Free standing base for perfect display placement.

