

# MPAO-X75ULL Outdoor Articulating Mount

## Universal Mount For 37-70" Displays

### Best In Class Outdoor Articulating Mount Solution

- Dacromet® coating provides year round protection against corrosion, rust, and all types of weather
- Universal design fits a wide variety of displays
- Lateral shift for perfect display placement
- Compatible with displays up to 130 lb and with VESA pattern up to 600 x 400mm
- Up to 15.5" of extension when fully extended
- Integrated cable management for a clean look



Model	Display Size	Max VESA	Total Load
MPAO-X75ULL	37" - 70"	600x400mm	130lb

#### DACROMET® PROTECTION

Fully shielded from Outdoor Elements

#### DUAL KEYED LOCKS

Locking Brackets for High Security

Both hanger brackets come equipped with steel keyed locks to prevent theft and unwanted tampering



#### LATERAL SHIFT AND LEVELING

Post-Installation Leveling Mechanisms

Post installation display adjustment allows for lateral (up/down) adjustment and individual side-to-side leveling for perfect placement

#### FULLY ADJUSTABLE ANGLES

Up to 41° Pivot and 15° Tilt

With more than 15" of full extension, the L also has up to 41° pivot and +15°/-5° of tilt, allowing for a wide variety of viewing angles



# MPAO-X75ULL Outdoor Articulating Mount

Universal mount for 30-70" displays



Ideal for outdoor applications, the MPAO-X75ULL is coated with Dacromet® finish to protect from the elements, while offering high functionality, aesthetics, and value. Dual locks ensure high security with the push of a key. Fits a huge variety of displays from 37-63" with through-cord cable management, post installation leveling, and tilting capability for easy display placement and adjustment.

Attribute	Value
Display size	30" - 70"
Weight capacity	130lb (59kg)
Max mounting pattern	723x501mm
Pivot	41°
Roll (side to side)	3°
Tilt	+15°/-15°
Depth from wall	3.8" (96.2mm)
Max extension	15.5" (394mm)
Construction	Aluminum/high-grade cold rolled steel
Product weight	21.8lb (9.9kg)
Product finish	Scratch resistant epoxy powder coat
Color	Black
Model number	MPAO-X75ULL
Warranty	Limited lifetime

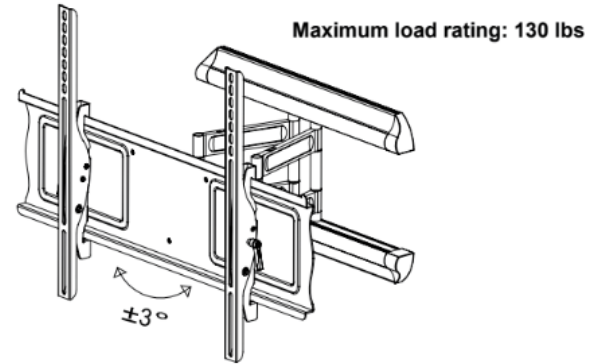
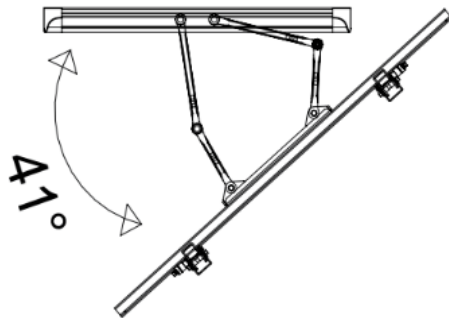

Maximum load rating: 130 lbs

