

1 2 3 4 5 6 7 8

D  
C  
B  
A

D  
C  
B  
A

Maximum load rating: 80 lbs

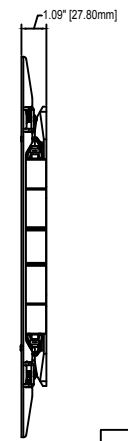
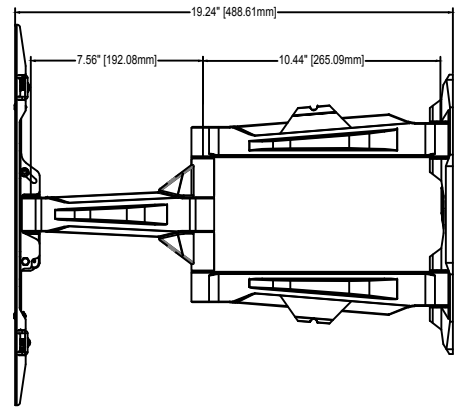
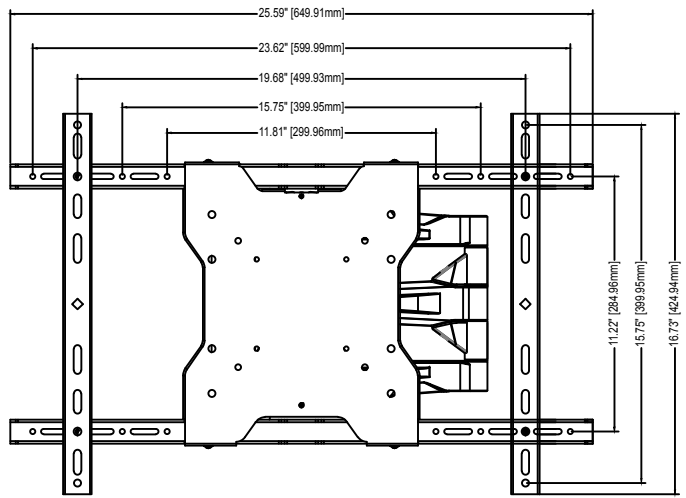
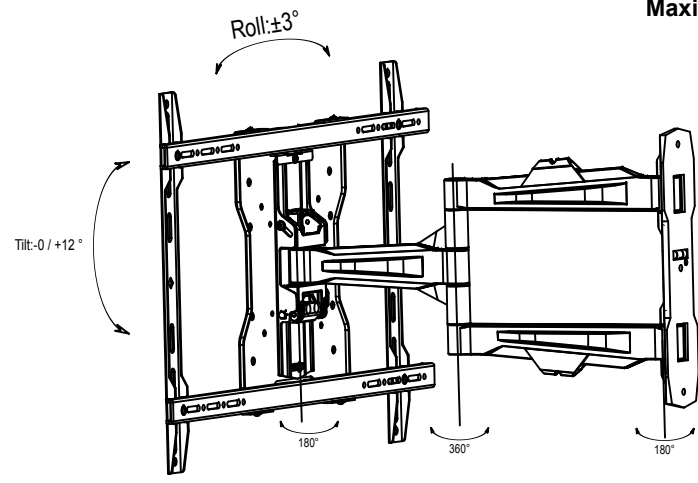
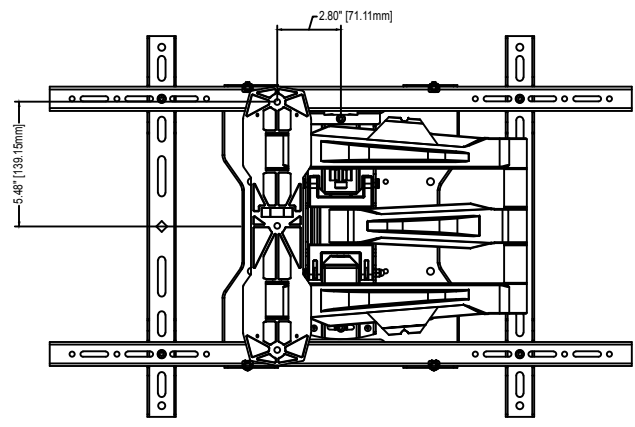

THE INFORMATION CONTAINED IN THIS DRAWING IS THE SOLE PROPERTY OF MUSTANG AV. ANY REPRODUCTION IN PART OR AS A WHOLE WITHOUT THE WRITTEN PERMISSION OF MUSTANG IS PROHIBITED



**MUSTANG AV**  
 PRODUCT ORDER NUMBER: **MPAU-L64U**  
 PHONE: **1-866-395-0370**

MUSTANG AV www.mustangav.com	
TITLE:	<b>MPAU-L64U</b>
DWG. NO. B	<b>MPAU-L64U</b>

Scale=1:1

1 2 3 4 5 6 7 8