

1 2 3 4 5 6 7 8

Maximum load rating: 100 lbs

D

C

B

A

D

C

B

A

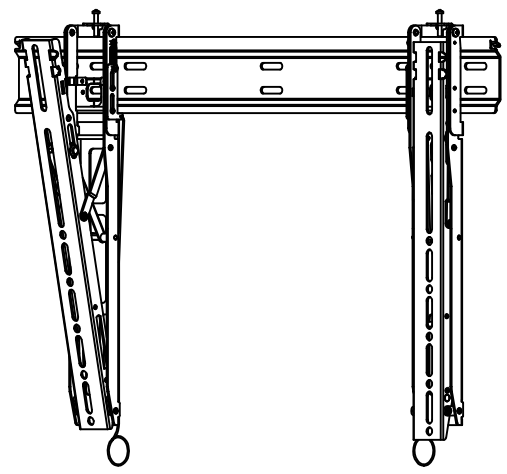
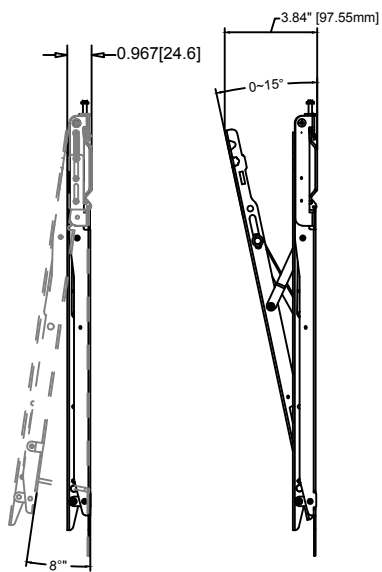
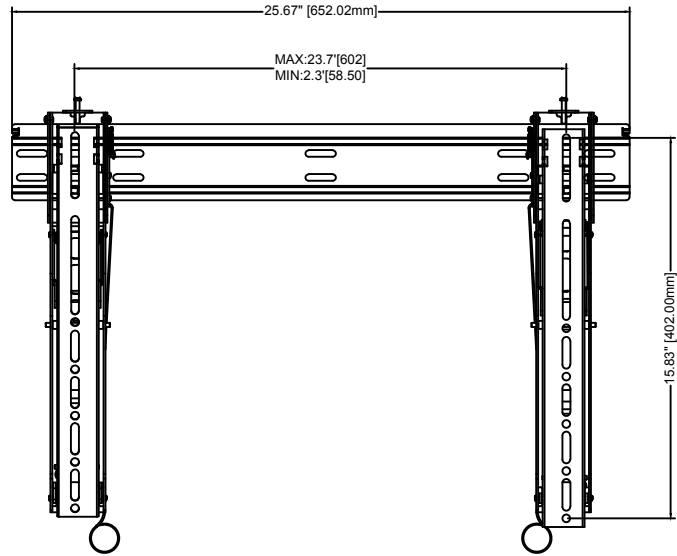

THE INFORMATION CONTAINED IN THIS DRAWING IS THE SOLE PROPERTY OF MUSTANG AV. ANY REPRODUCTION IN PART OR AS A WHOLE WITHOUT THE WRITTEN PERMISSION OF MUSTANG AV IS PROHIBITED



MUSTANG AV

PRODUCT ORDER NUMBER: MPTU-L64U
PHONE: 1-866-395-0370

MUSTANG AV	
www.mustangav.com	
TITLE:	MPTU-L64U
SIZE/DWG. NO.	MPTU-L64U

Scale=1:1

1 2 3 4 5 6 7 8