

1

2

3

4

5

6

7

8

Maximum load rating: 300 lbs

D  
C  
B  
A

D  
C  
B  
A

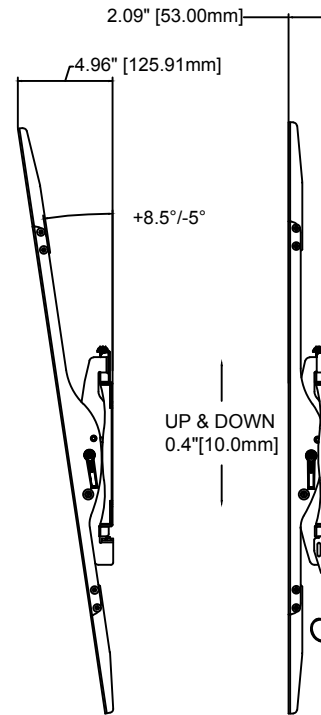
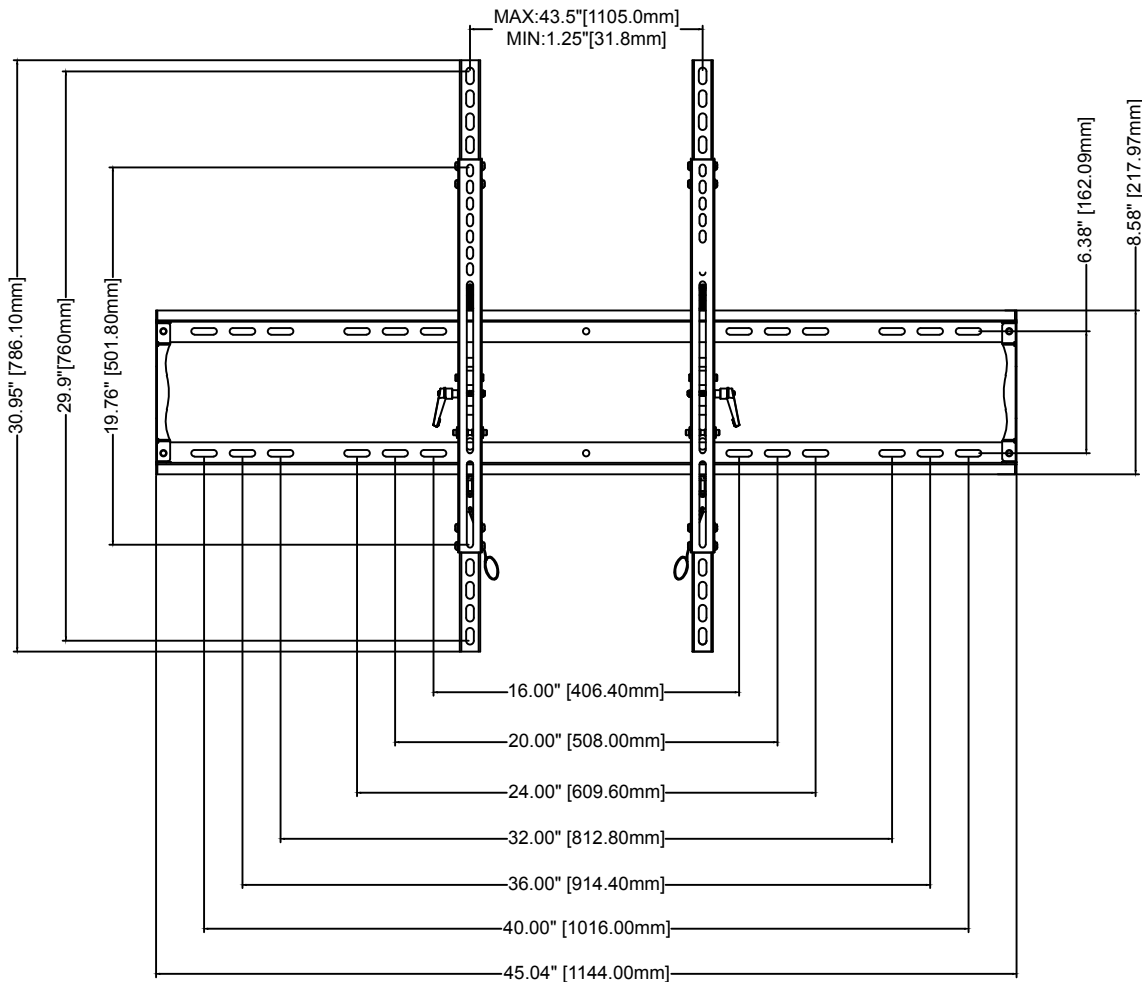

THE INFORMATION CONTAINED IN THIS DRAWING IS THE SOLE PROPERTY OF MUSTANG AV. ANY REPRODUCTION IN PART OR AS A WHOLE WITHOUT THE WRITTEN PERMISSION OF MUSTANG AV IS PROHIBITED



MUSTANG AV

PRODUCT ORDER NUMBER: **MPT-X116A**  
PHONE: **1-866-395-0370**

MUSTANG AV www.mustangav.com	
TITLE:	<b>MPT-X116A</b>
SIZE No.	<b>MPT-X116A</b>

Scale=1:1

1

2

3

4

5

6

7

8