

1 2 3 4 5 6 7 8

Maximum load rating: 40 lbs

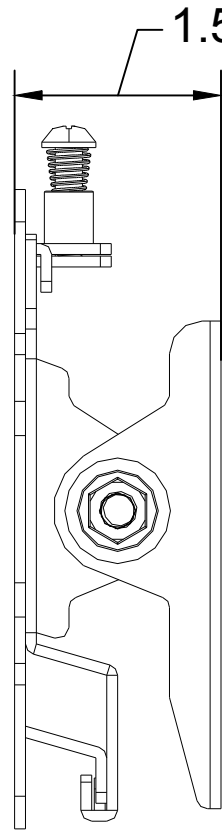
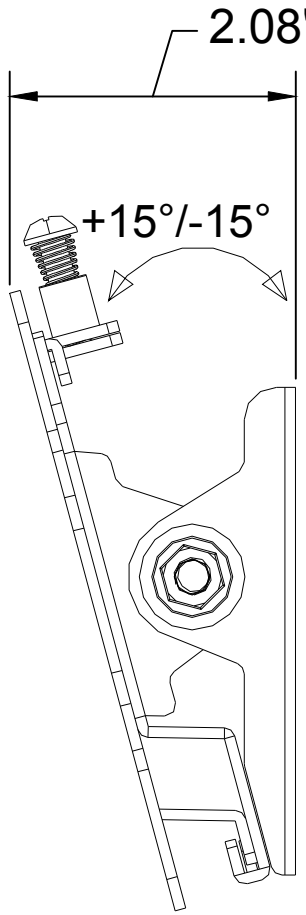
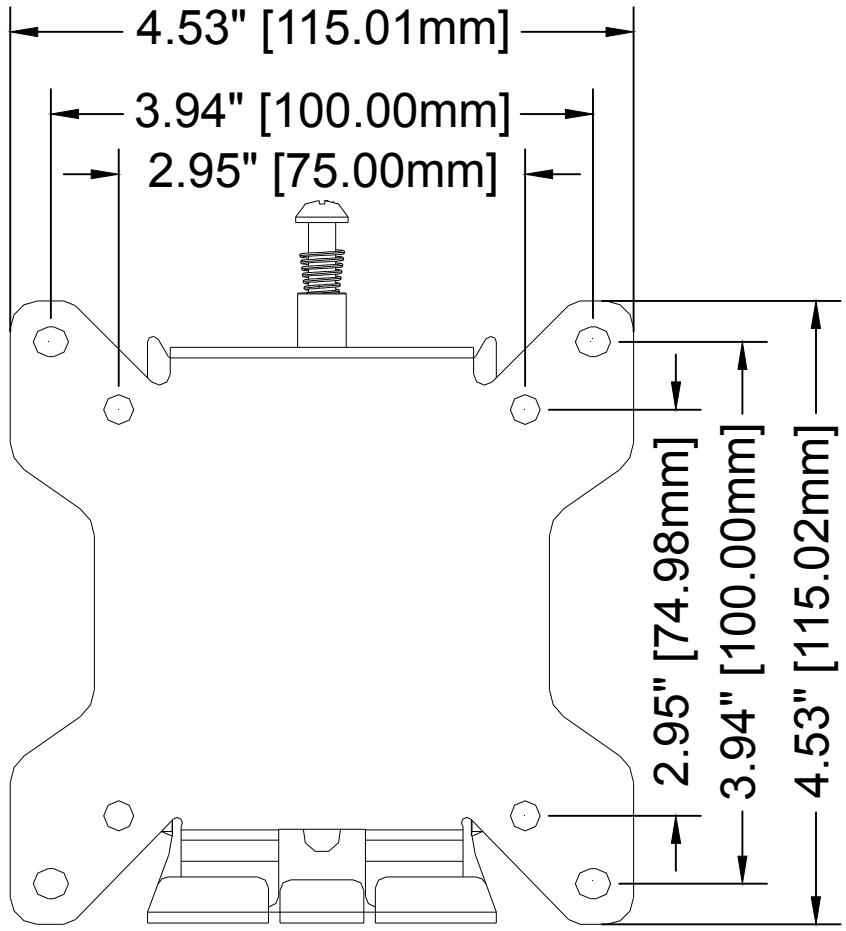

D
C
B
A

D
C
B
A

THE INFORMATION CONTAINED IN THIS DRAWING IS THE SOLE PROPERTY OF MUSTANG AV. ANY REPRODUCTION IN PART OR AS A WHOLE WITHOUT THE WRITTEN PERMISSION OF MUSTANG AV IS PROHIBITED



MUSTANG AV

PRODUCT ORDER NUMBER: **MPT-S11V**
PHONE: 1-866-395-0370

Scale=1:1

MUSTANG AV www.mustangav.com	
TITLE:	MPT-S11V
SIZE NO. B	MPT-S11V

1 2 3 4 5 6 7 8