

Maximum load rating: 150 lbs

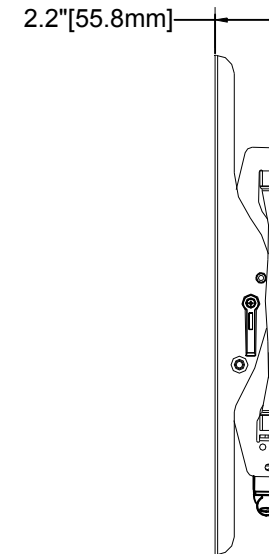

THE INFORMATION CONTAINED IN THIS DRAWING IS THE SOLE PROPERTY OF MUSTANG AV. ANY REPRODUCTION IN PART OR AS A WHOLE WITHOUT THE WRITTEN PERMISSION OF MUSTANG AV IS PROHIBITED

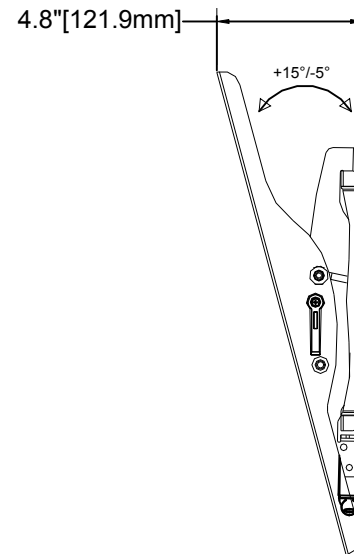
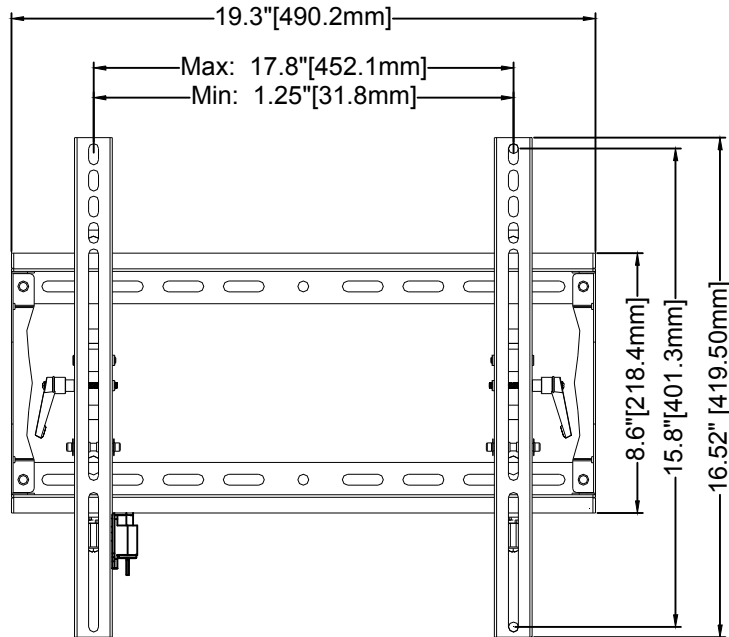
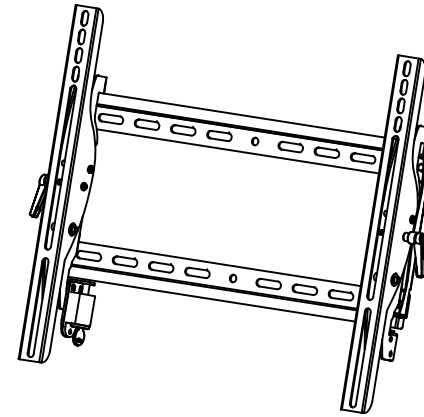

MUSTANG AV

PRODUCT ORDER NUMBER: **MPT-M44UL**  
PHONE: **1-866-395-0370**

MUSTANG AV  
www.mustangav.com

TITLE:

**MPT-M44UL**

SIZE  
DWG. NO.

**MPT-M44UL**

Scale=1:1