

1 2 3 4 5 6 7 8

Maximum load rating: 150 lbs

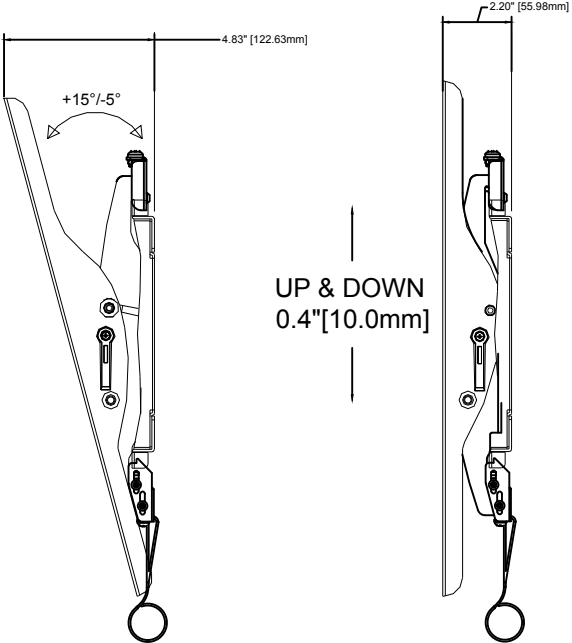

THE INFORMATION CONTAINED IN THIS DRAWING IS THE SOLE PROPERTY OF MUSTANG AV. ANY REPRODUCTION IN PART OR AS A WHOLE WITHOUT THE WRITTEN PERMISSION OF MUSTANG AV IS PROHIBITED

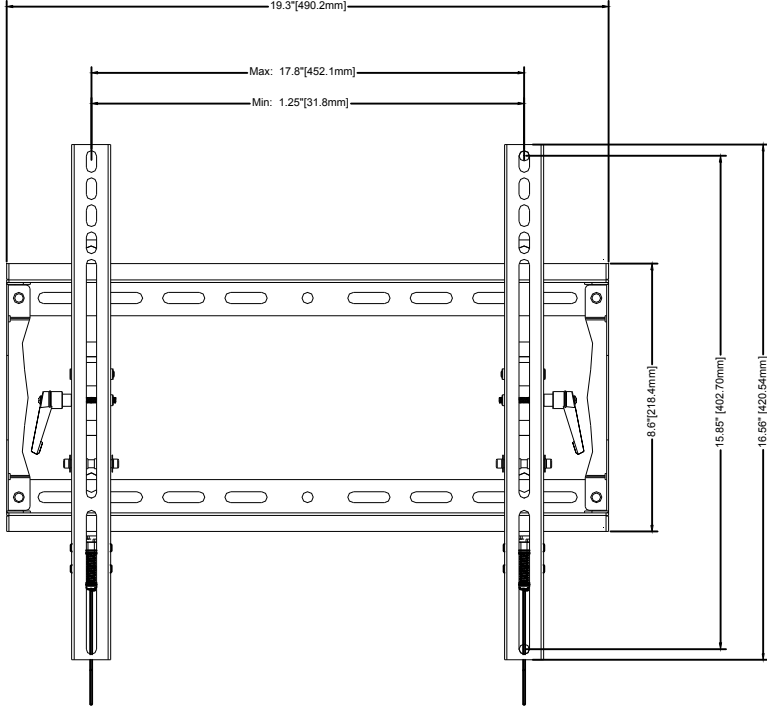

MUSTANG AV

PRODUCT ORDER NUMBER: **MPT-M44UA**
 PHONE: **1-866-395-0370**

Scale=1:1

MUSTANG AV www.mustangav.com	
TITLE:	MPT-M44UA
SIZE DWG. NO.	MPT-M44UA

1 2 3 4 5 6 7 8