



Professional Solutions - Unrivalled Value

Ideal for components weighing up to 50lb (22.7kg) and may be used with wall mounted TV or as a stand-alone wall unit. Easy to install, with limitless shelf height adjustment. 6mm tempered glass that sits only 1.18" from the wall. Integrated cable management for a clean look.

 50 LB / 22.7 KG

Functional Specifications

Depth from wall: 1.18" (30mm)

Mounting Surfaces: Wood stud, concrete & cinder block (with included hardware). Drywall (requires accessories).

Load Capacity: 50 LB / 22.7 KG

Warranty: Limited 10 Years

■ Appearance

Black smoke tempered glass.

■ Adjustable

Continuous height adjustment, no tools required.

■ Easy Installation

Mounts to a single stud, concrete or other structural surface. Also may be mounted directly on drywall using the MPHT-2 hardware

■ Cable Management

Integrated cable management for clean look.

■ Included Hardware

Pre-sorted hardware pack for easy component selection and installation (hardware for installation to wood studs or concrete surfaces included).



Adjustable Shelf
Limitless height adjustment without use of tools.



Cord Management
Integrated cord management for clutter-free installation.



Flexibility
Choose between one, two or three shelves for a custom wall system.

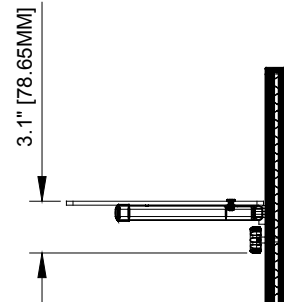
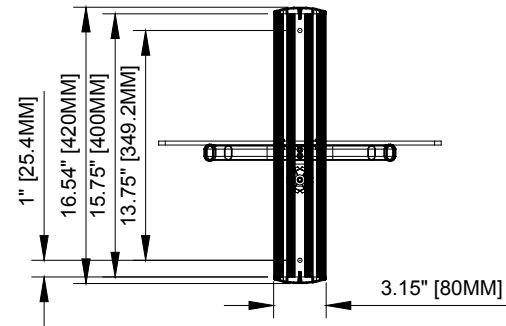
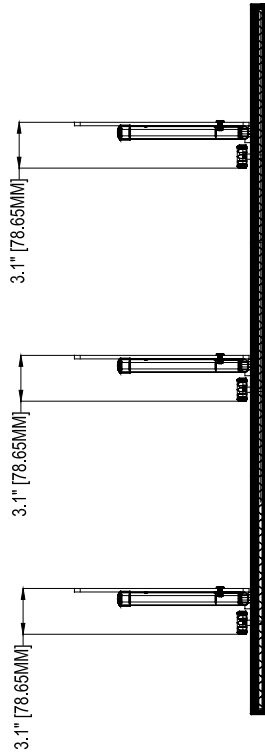
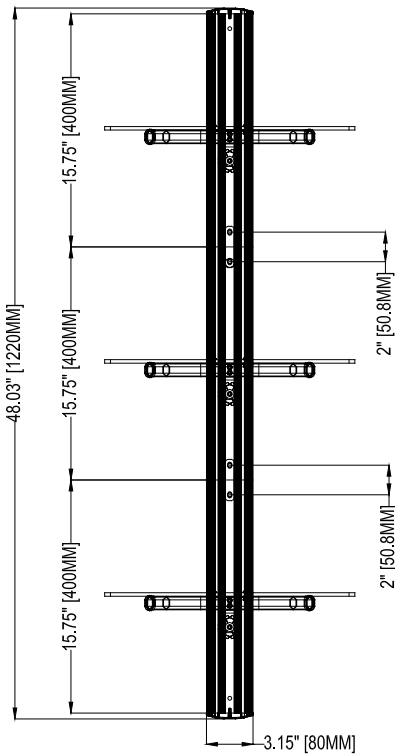
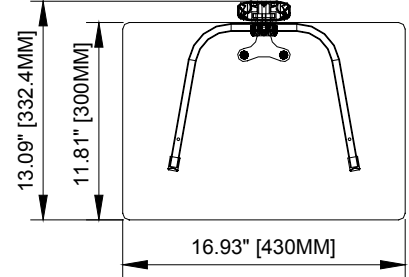
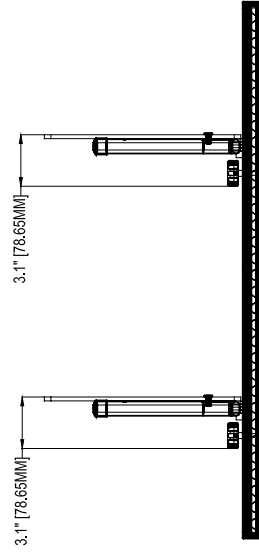
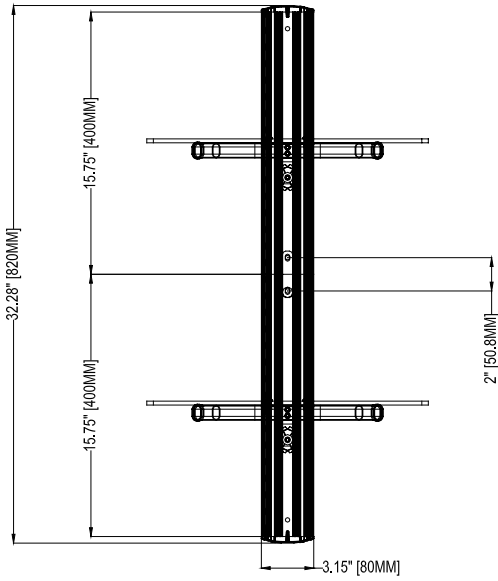

Product Specifications

Package Specifications

PRODUCT WEIGHT	LOAD CAPACITY	COLORS	FINISH	PACKAGE SIZE (WxHxD)	SHIP WEIGHT	UPC CODE	PACKAGE CONTENTS
5.1lb (2.3kg) MPWA-1	50lb (22.7kg) per shelf	Black	Tempered Glass	18.9" x 5.5" x 2.4"	7.3lb (3.3kg)	MPWA-1	Glass shelves, wall mounting hardware, product manual.
10.1lb (4.6kg)				34.6" x 5.5" x 2.4"	14.6lb (6.6kg)	MPWA-2	
				50.4" x 5.5" x 2.4"	22lb (9.9kg)	MPWA-3	

Visit mustangav.com to see the full line of vidamounts LCD/plasma, projector and TV/monitor mounts.